

REINHOLD ENVIRONMENTAL Ltd.



2017 NO_x-Combustion-CCR Round Table Presentation

February 27 & 28, 2017, in Cleveland, OH / Hosted by FirstEnergy

All presentations posted on this website are copyrighted by Reinhold Environmental, Ltd (RE). Any unauthorized downloading, attempts to modify or to incorporate into other presentations, link to other websites, or obtain copies for any other uses than the training of attendees to RE's Conferences is expressly prohibited, unless approved in writing by RE or the original presenter. RE does not assume any liability for the accuracy or contents of any materials contained in this library which were presented and/or created by persons who were not employees of RE.

Ammonia Mixing Issues and Lessons Learned

2017 NO_x-Combustion-CCR Round Table
27 February 2017

Robert Mudry, P.E.
Airflow Sciences Corporation
rmudry@airflowsciences.com
734-525-0300

Agenda

- ❖ Intro
 - ❖ Coal Fired SCR
 - ❖ Gas Turbine SCR
 - ❖ Videos
 - ❖ Summary
-
- ❖ Audience participation encouraged

From Webster's Dictionary

Mix (verb):

- (1) : to combine or blend into one mass
- (2) : to combine with another
- (3) : to bring into close association
- (4) : to form by mixing components
- (5) : to confuse -- often used with *up*



How Do You Mix?

- ❖ Control the flow streams at the merger location
 - Multi-point injection
 - Layered injection
 - Diffusion + turbulence
- ❖ Churn up the flow after the merger
 - Induce high turbulence
 - Create shear forces
 - Generate swirl or vortices

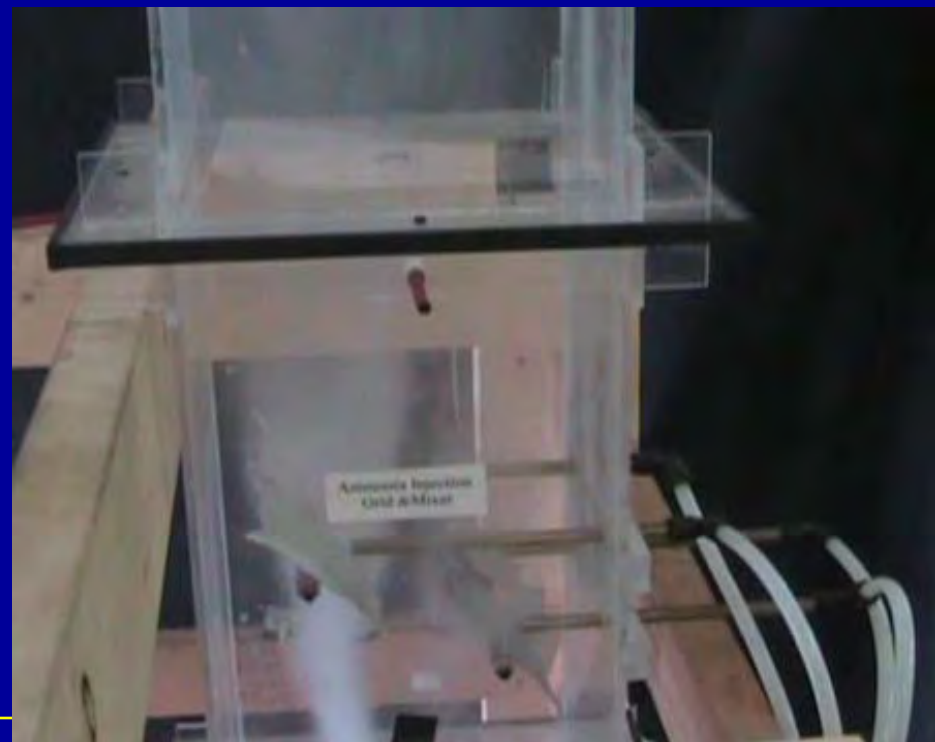
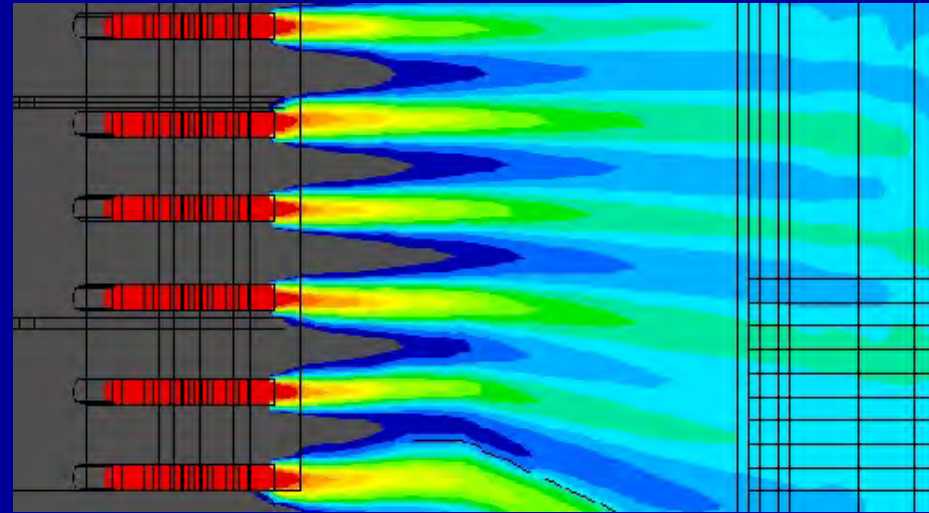

Where do you mix?

❖ Coal Fired SCR

- NO_x, temperature –
 - upstream AIG
 - “Premixer”
- NH₃ – at or after AIG

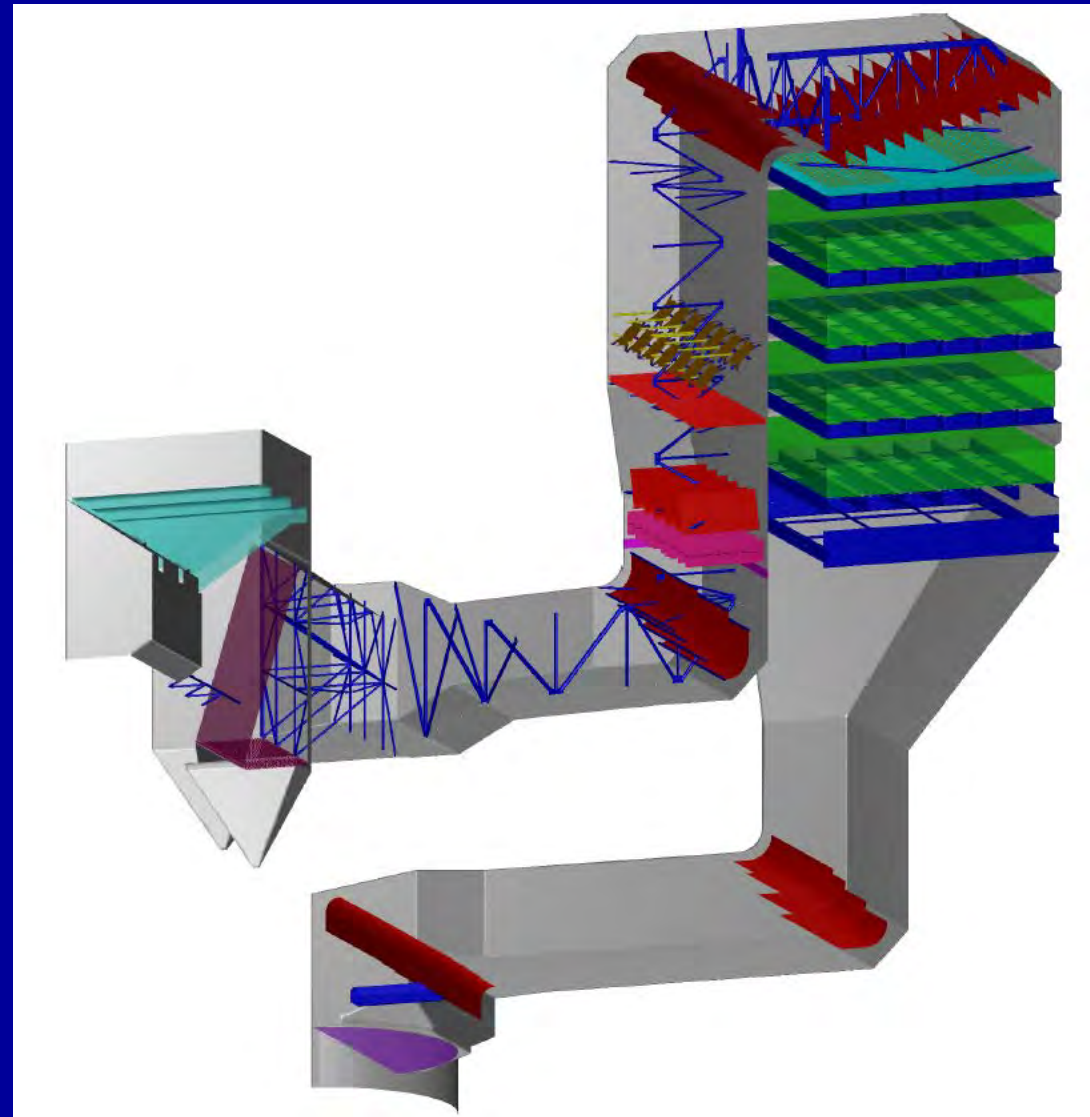

Where do you mix?

❖ Gas Turbine SCR

- NO_x – uniform?
- Temperature
 - Upstream CO catalyst
- NH₃ – at or after AIG



Coal Fired SCR

❖ Typical performance goals compete with each other

- Uniform ammonia-to-NOx ratio ←
- Uniform velocity at AIG and catalyst ←
- Vertical flow entering catalyst
- Uniform temperature at catalyst
- Capture LPA with screen/baffles
- Minimize pressure loss
- Minimize erosion potential
- Minimize pluggage potential



Ammonia-to-NO_x Ratio

- ❖ Ammonia-to-NO_x ratio at the catalyst inlet plane should be “uniform”
- ❖ Allows optimal NO_x reduction with minimum ammonia slip
- ❖ Typical goal is %RMS < 5% or deviation within +/-5% of mean
- ❖ Can be highly influence by velocity patterns



NO_x Stratification

- ❖ NO_x is not necessarily uniform at the boiler exit; it is a function of
 - Boiler design
 - Burner air flow balance
 - Coal pipe balance
 - Mills out-of-service
- ❖ Solutions
 - Mix the NO_x prior to the NH₃ injection – “Pre-mixer”
 - Mix the NO_x and the NH₃
 - Tune the NH₃ to the NO_x profile
 - Consistency over load range important



Ammonia Injection

- ❖ Two basic strategies are used for ammonia injection in SCRs
 - Dense grid of injection pipes
 - Coarse grid of injection pipes with mixers



Dense Grid Ammonia Injection

- ❖ Many injection lances with multiple nozzles per lance
 - Depending on SCR size, could have 50-100 lances per reactor inlet duct
 - Typically 6-10 nozzles per lance
 - Hundreds of discrete injection points
- ❖ Lances grouped into zones for tuning
- ❖ Often no mixer or only a “local” mixer



Dense Grid AIG Benefits

- ❖ More tunable for maximum NO_x reduction
 - Is this true?
 - More levers does mean more complexity
- ❖ No negative influence on velocity or flyash distribution at catalyst
- ❖ Lower pressure drop

Dense Grid AIG Issues

- ❖ Requires very good velocity profile at AIG location
- ❖ Pluggage of nozzles
- ❖ Tuning not as predictable as sometimes envisioned
 - Velocity distribution issues
 - Unequal flow per nozzle
 - Low resolution of reactor outlet sample grid
- ❖ Valve issues over time
- ❖ What has the audience experienced?



Coarse Grid Ammonia Injection

- ❖ Fewer injection lances compared to dense grid by factor of 5-10
 - Depending on SCR size, could have 5, 10, 20 lances per reactor
 - Some systems have just 1 injection point per lance
 - Others have multiple nozzles per lance (2 to 10)
- ❖ Lances located immediately upstream of a static mixer
- ❖ Often multiple stages of static mixers

Coarse Grid AIG Benefits

- ❖ Fewer nozzles and larger openings less prone to pluggage
- ❖ Mixing and high turbulence reduces sensitivity of gradients
 - Does not need as much tuning?
 - More consistent performance over the load range?

Coarse Grid AIG Issues

- ❖ Tuning not as straight-forward due to purposeful creation of turbulence
- ❖ Duct wall and internal structure erosion
- ❖ Higher pressure loss
- ❖ Ash accumulation on mixers

- ❖ What has the audience experienced?

Shear Mixer



Shear Mixer

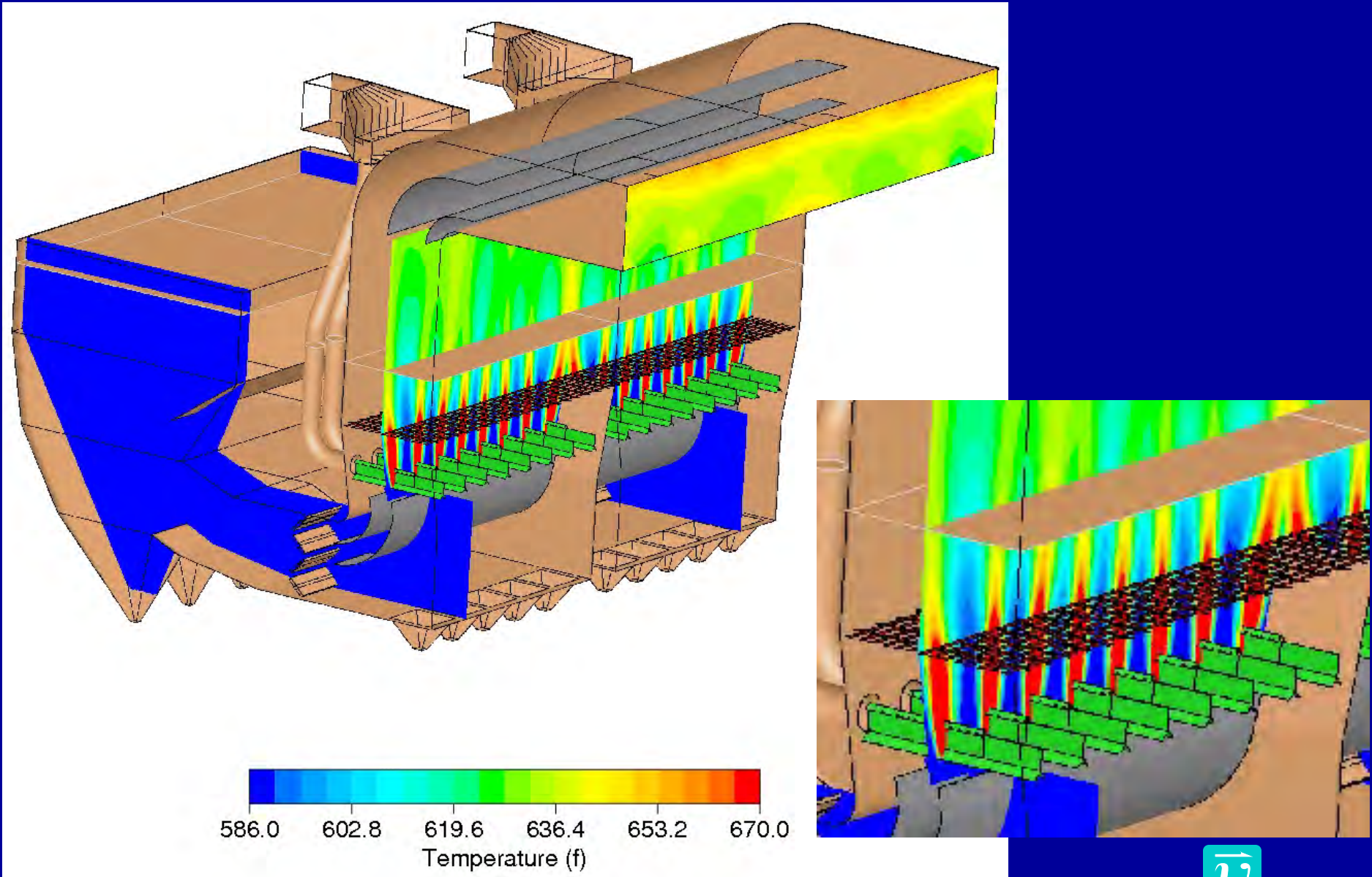

Shear Mixer

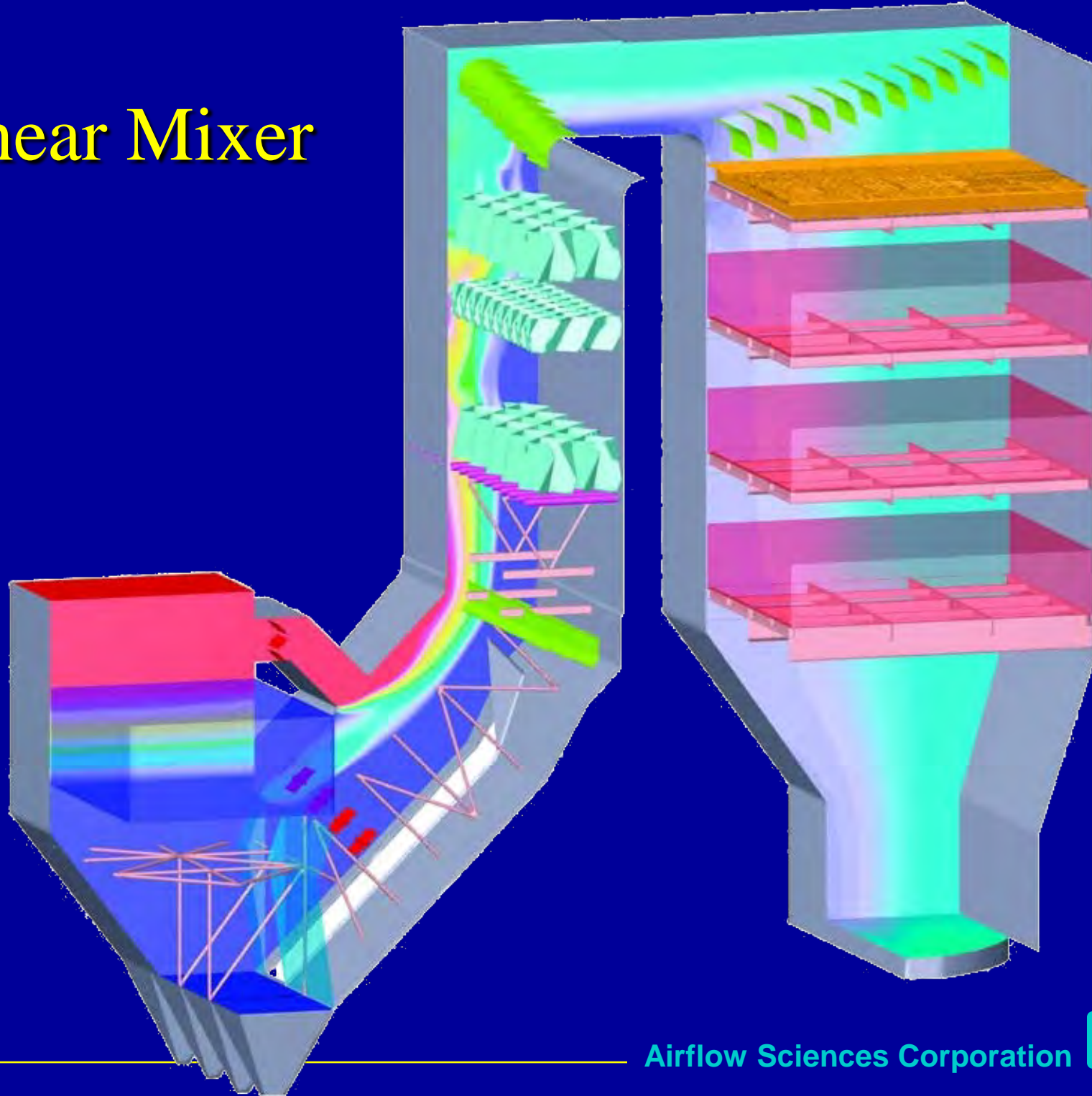

Swirl - Shear Mixer

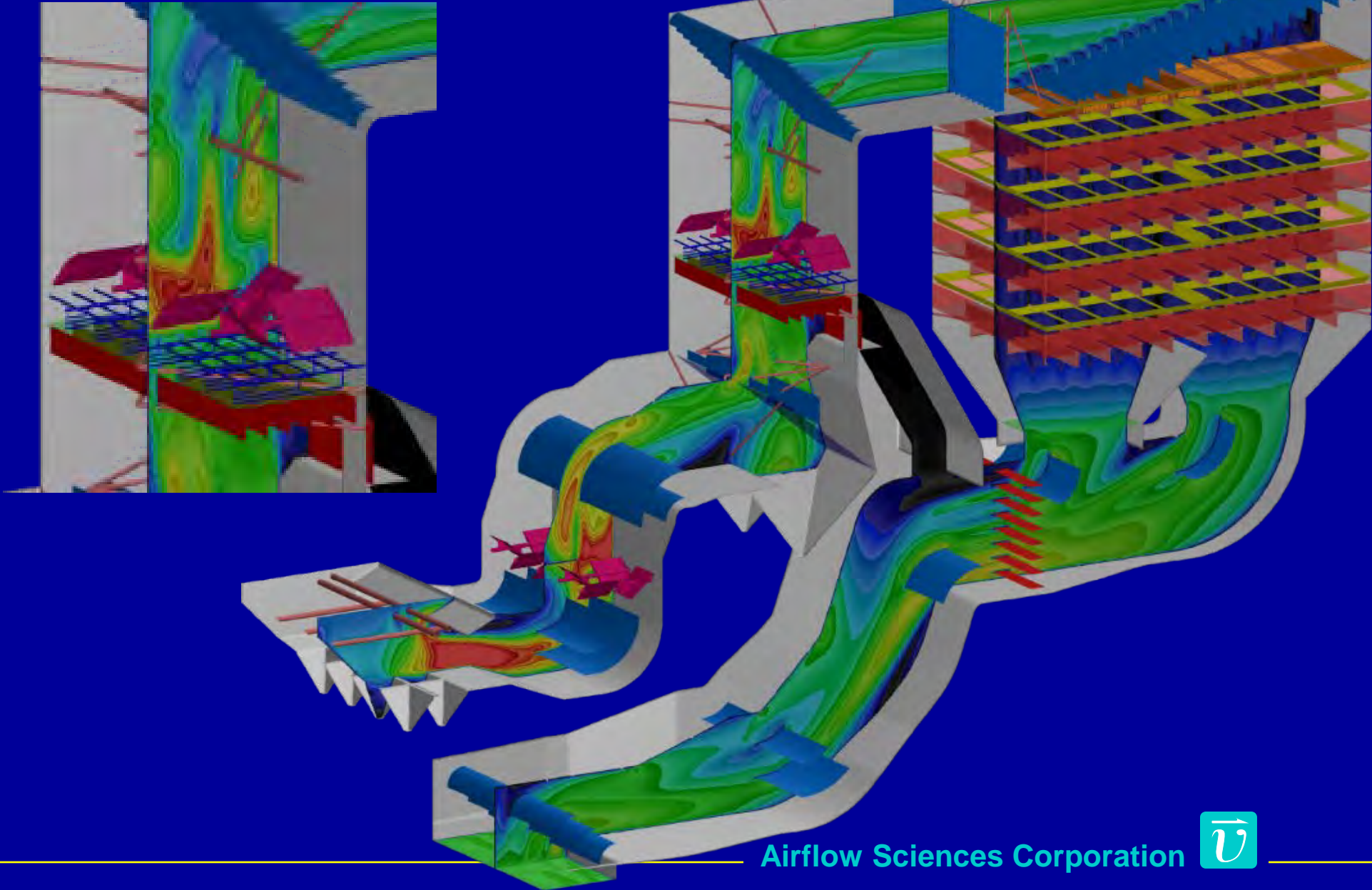

Vortex Mixer

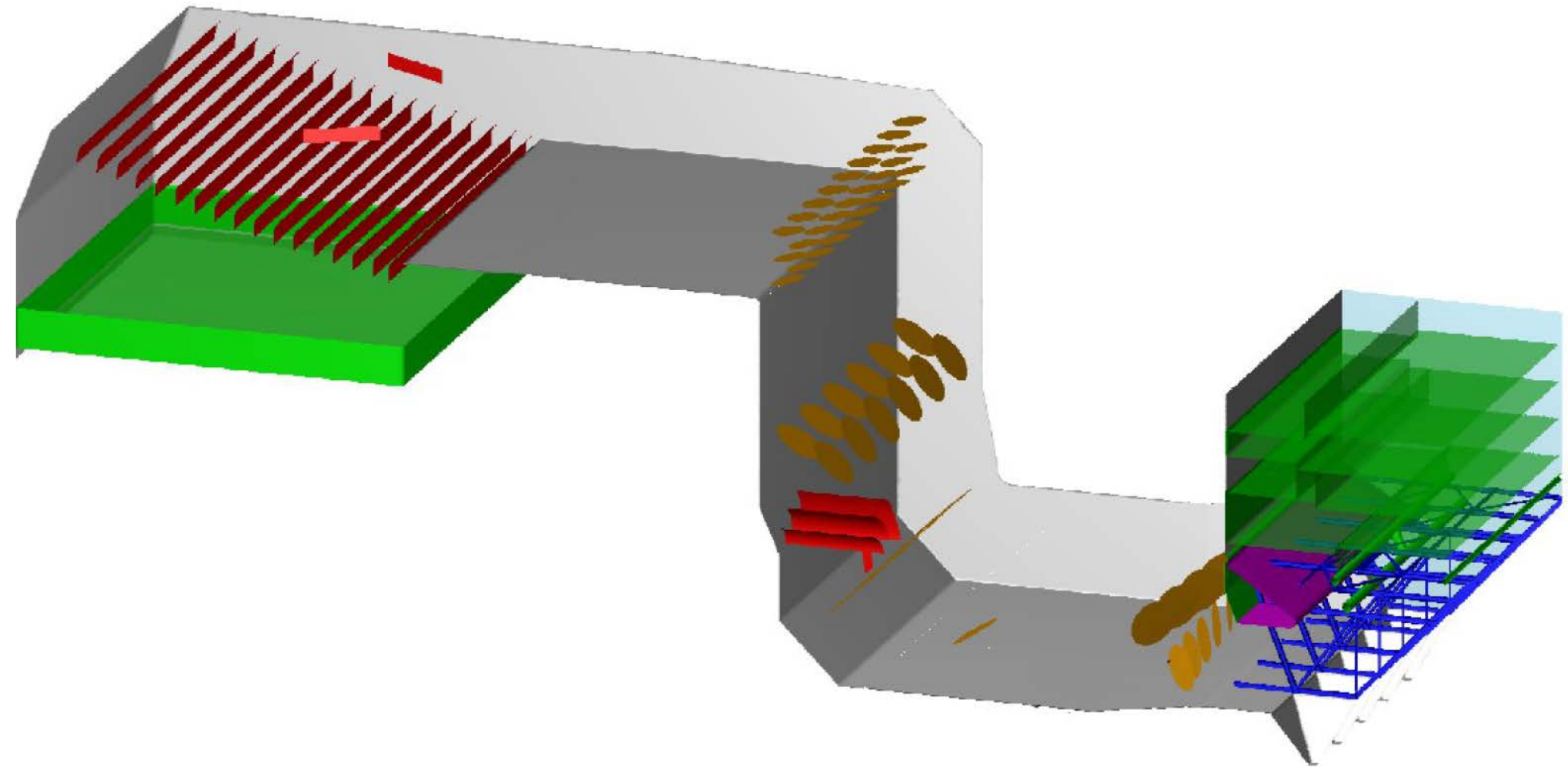

Vortex Mixer



Economizer outlet,
compilation photo of mixer plates
(flow is into page)



Vortex Mixer

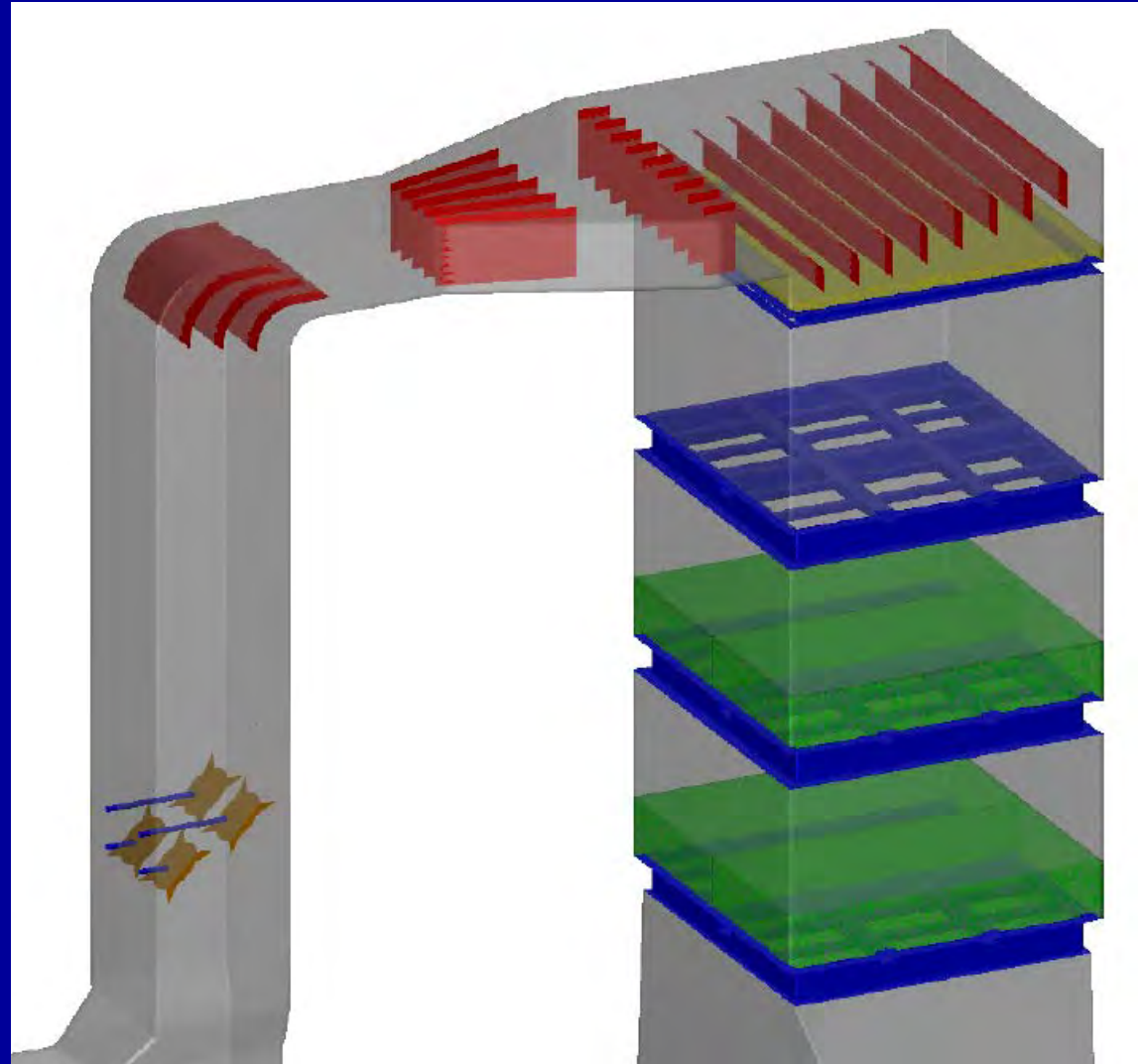

Vortex Mixer

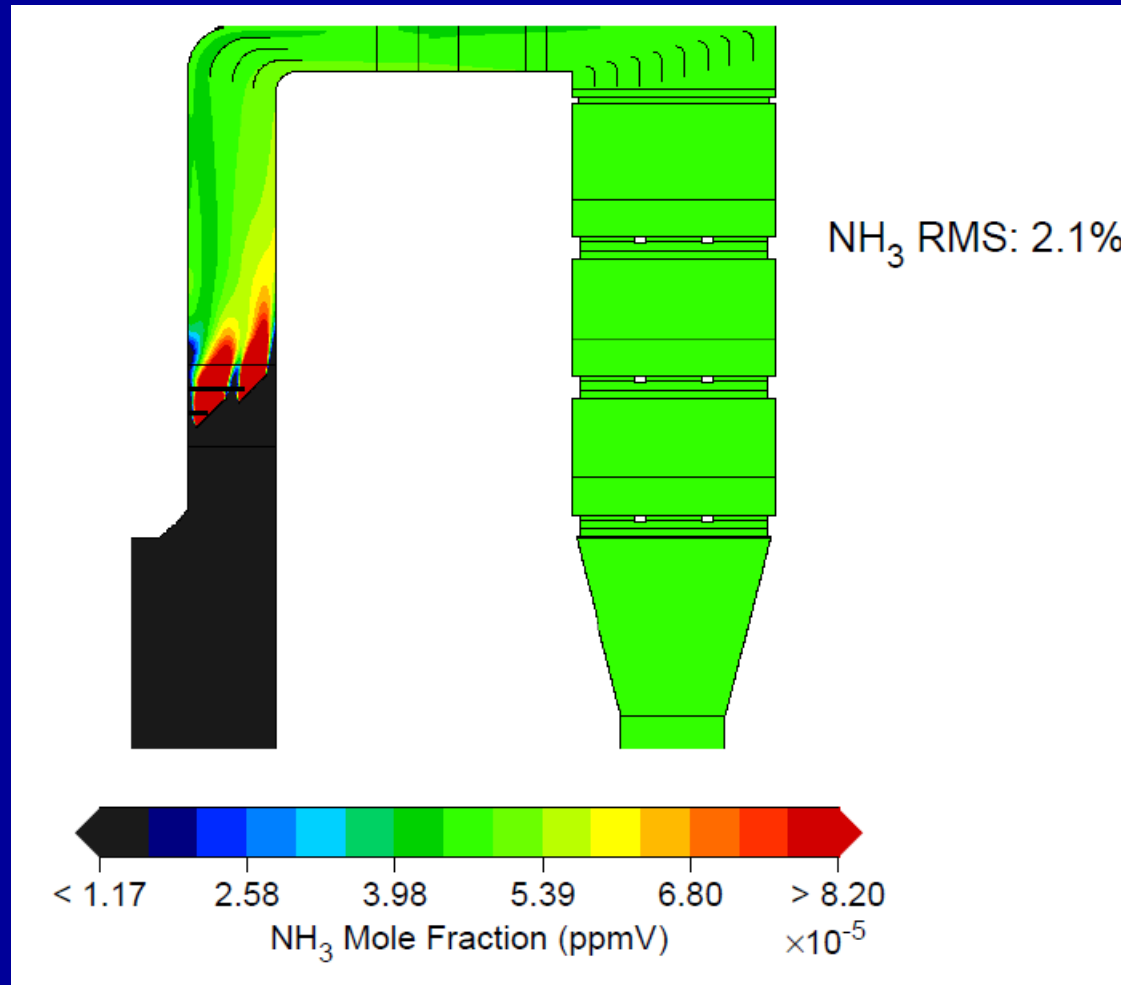

Vortex Mixer

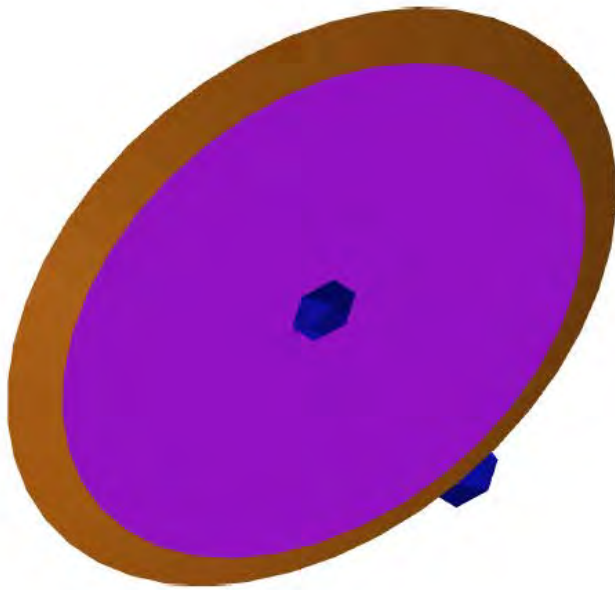

Geometry

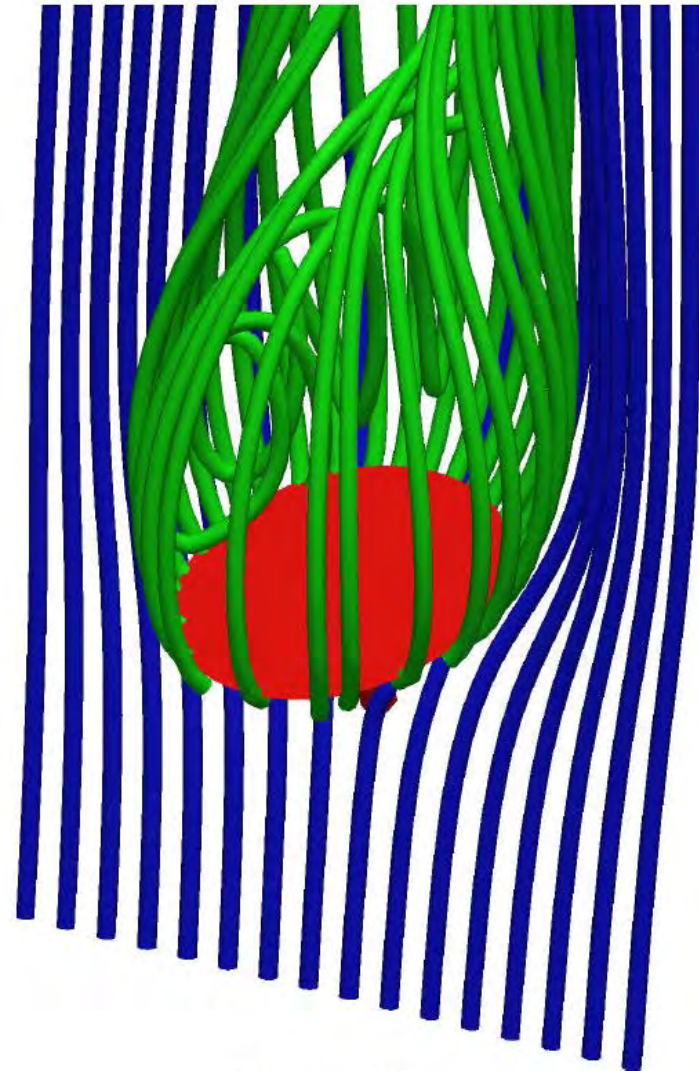

Fluid path lines

Vortex Mixer



Geometry

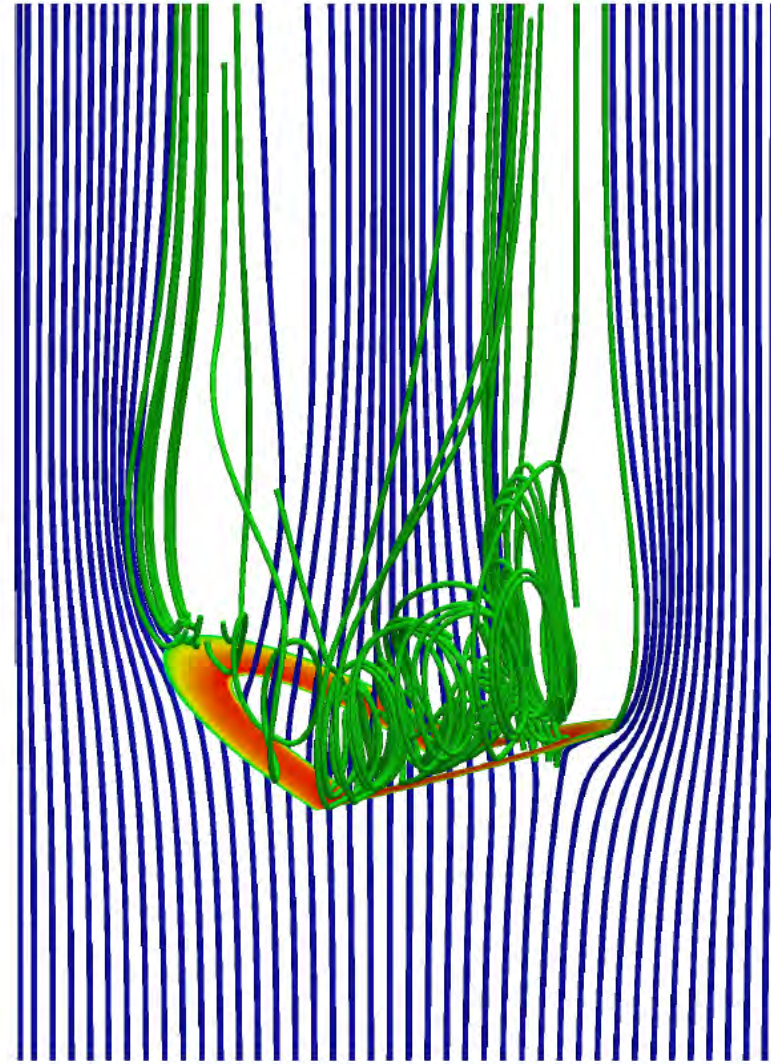

Fluid path lines

Vortex Mixer

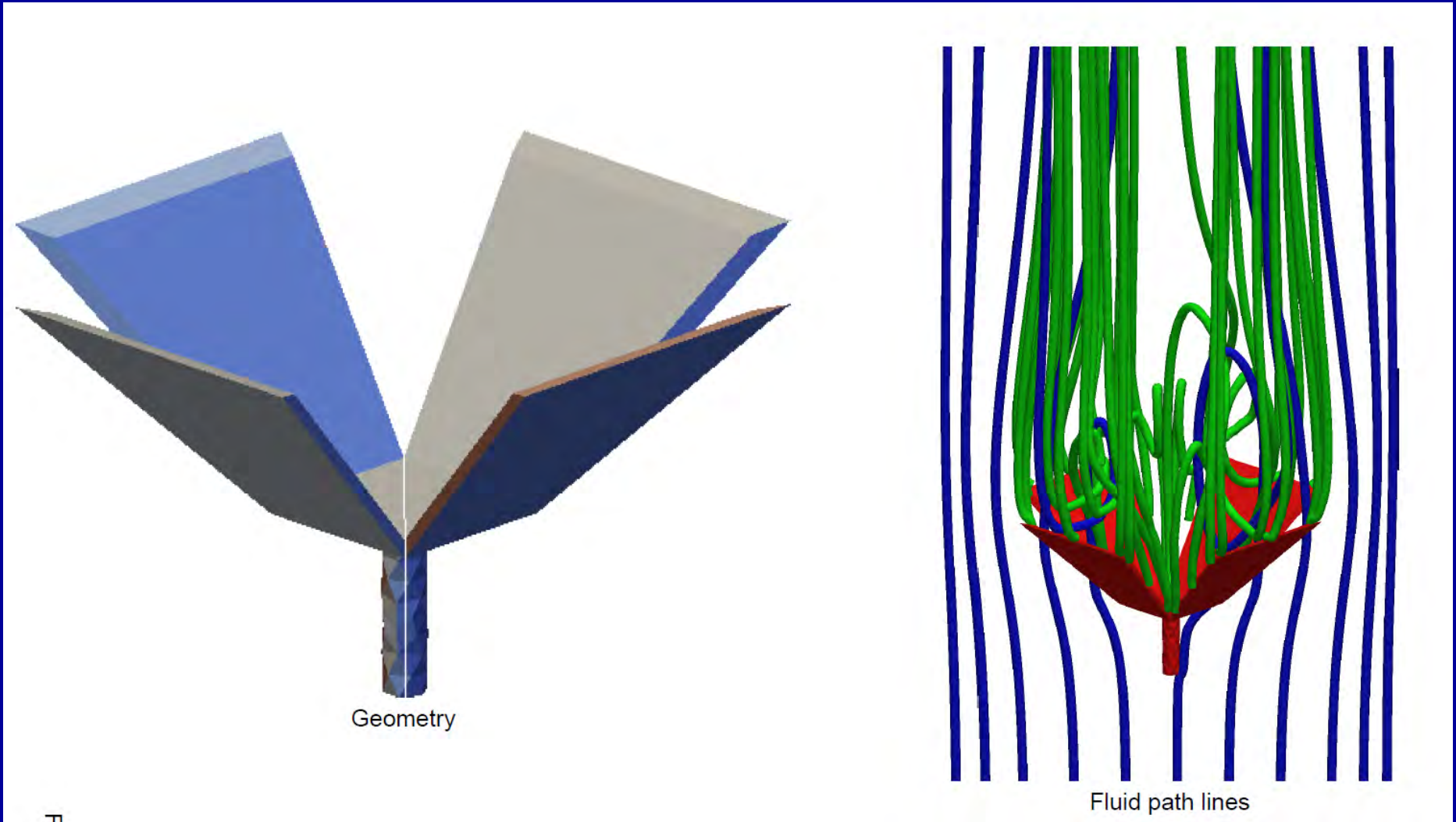

Vortex - Shear Mixer



Mixer Issues - Erosion

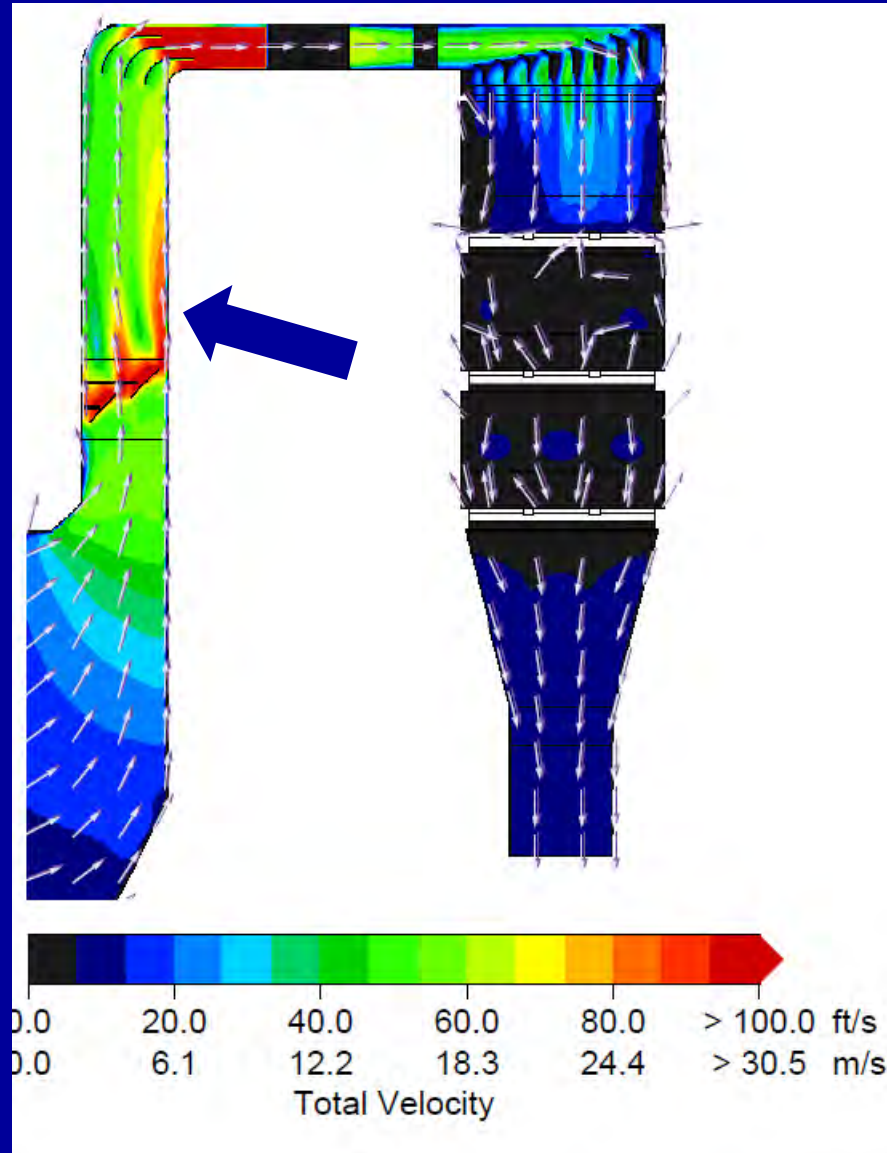

Mixer Issues - Erosion

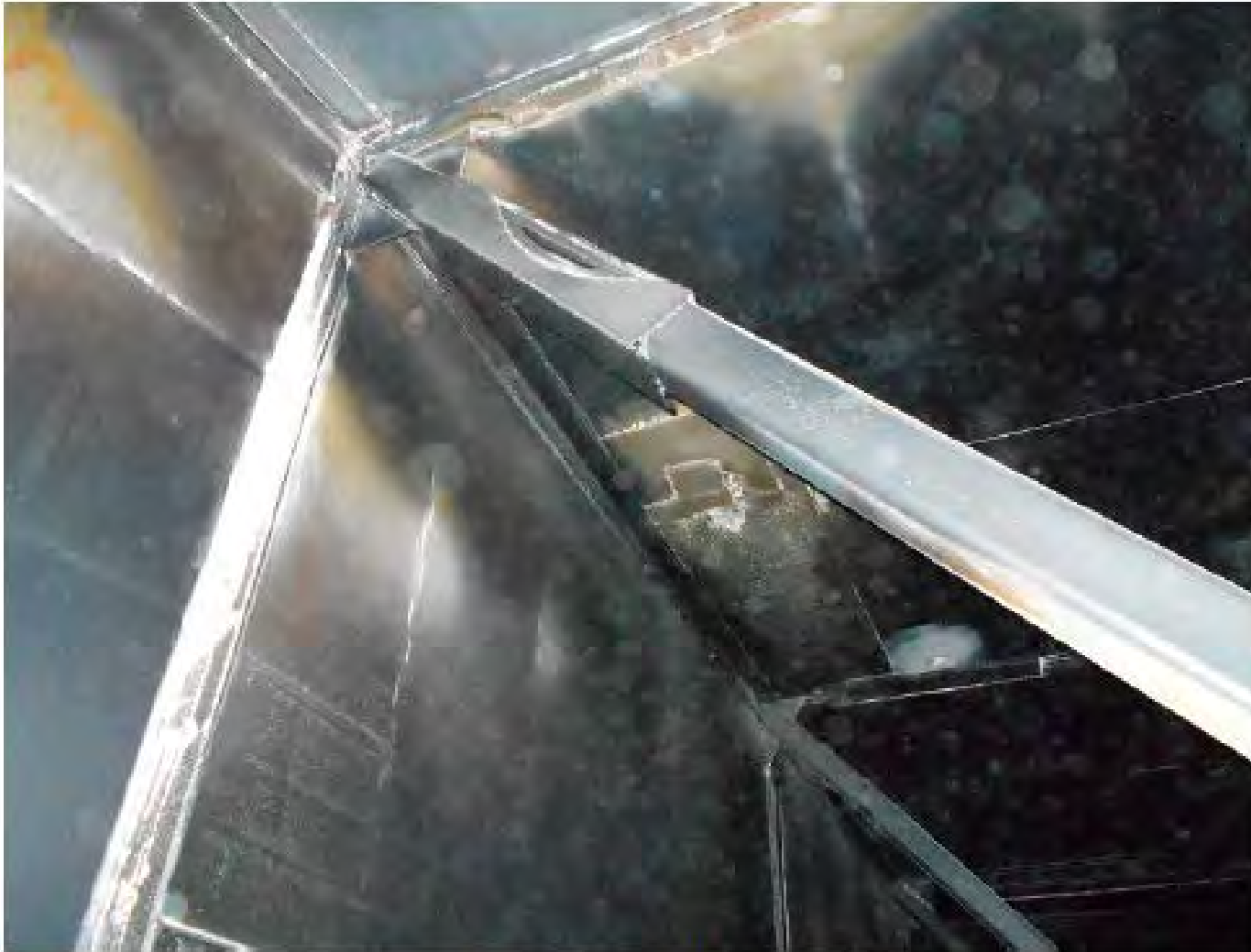

Internal truss erosion downstream of mixers
(zoomed view at right)

Mixer Issues - Erosion



Duct roof erosion downstream of mixers, near unit centerline (flow is left to right)
(zoomed view at right; repair patches evident)

Mixers– Pressure Drop

	Location	Total Pressure Loss (inH2O)	Total Pressure Loss (mmH2O)
A	Evaporator Outlet	0	0
B	Upstream AIG	-0.03	-0.8
C	Downstream AIG	-0.75	-19.1
D	Upstream SCR Duct Expansion	-0.95	-24.1
E	Downstream SCR Duct Expansion	-1.07	-27.1
F	Upstream Flow Rectifier	-1.23	-31.2
G	Upstream (Future) 1st Catalyst Layer	-1.26	-32.1
H	Upstream 2nd Catalyst Layer	-1.29	-32.7
I	Upstream 3rd Catalyst Layer	-2.30	-58.3
J	Downstream 3rd Catalyst Layer	-3.29	-83.7
K	Economizer Inlet	-3.31	-84.0
A-K	Total DP, Evaporator Outlet to Economizer Inlet	3.31	84.0
A-K	Total DP, Excluding Catalyst Layers	1.27	32.3

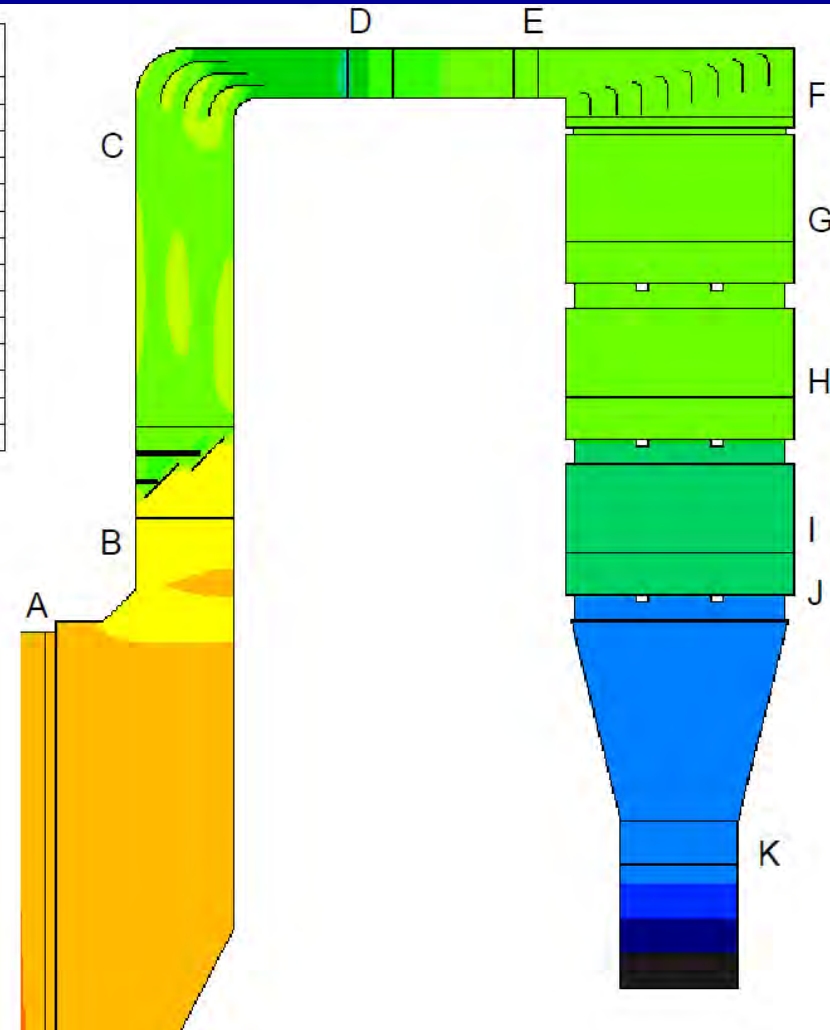

DP = 0.72 IWC

Typical mixer stage
DP = 0.3 to 0.8 IWC

Summary – Coal Fired SCR

- ❖ The NH_3 , NO_x , and temperature distributions are key players in SCR performance
- ❖ Pre-mixer often used for NO_x and temperature at boiler outlet
- ❖ Dense Grid AIG generally no mixer or “local” mixer
- ❖ Coarse Grid AIG will have 1 or more high turbulence mixer layers
- ❖ AIG and mixer design involves many competing criteria which must be understood and optimized



Videos



Gas Turbine SCR

- Gas turbines come in many sizes and flavors
 - Simple cycle
 - Combined cycle / HRSG
 - With / without CO catalyst
 - With / without tempering air



Gas Turbine SCR

- ❖ Typical performance goals compete with each other
 - Uniform ammonia-to-NOx ratio ←
 - Uniform velocity at AIG and catalyst ←
 - Uniform temperature at catalyst
 - Minimize pressure loss
 - Uniform velocity at CO catalyst
 - CO catalyst influence on SCR



GT Design Objectives

❖ Flow

- Uniform velocity profile (15% RMS) at
 - CO catalyst
 - AIG
 - SCR catalyst
 - Tube banks
 - Stack CEMs
- Not easy given the inlet condition is a tornado
- Requires intricate design of devices
 - Baffles
 - Straighteners
 - Perforated plates

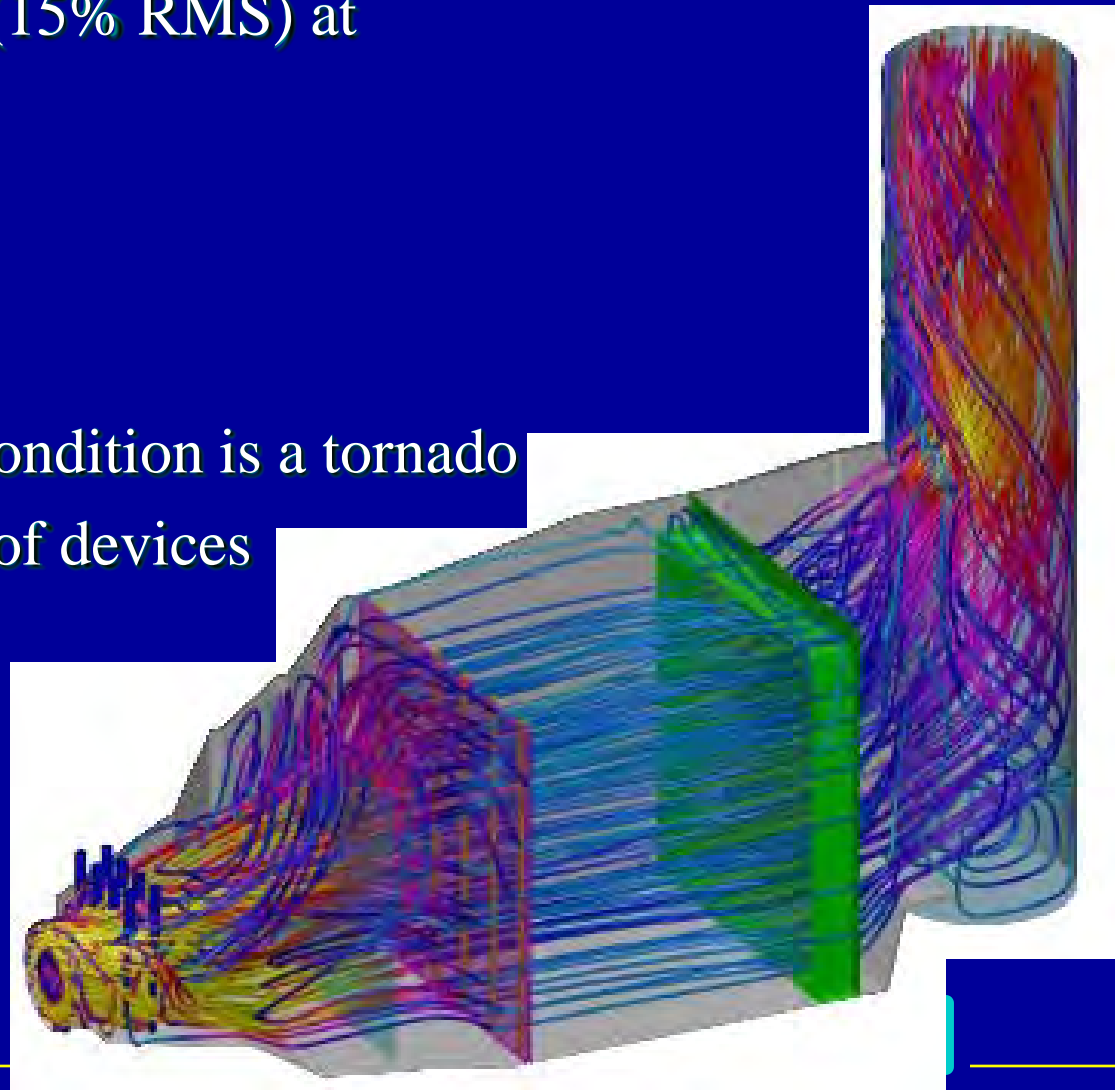

GT Design Objectives

❖ Gas Temperature

- Heat transfer to tube banks / HRSG important
- Uniformity at catalyst (CO, NO_x) affects performance
 - Typical goal +/-50 F
 - Can be challenging if significant amount of tempering air
 - Temperature is not necessarily uniform exiting the turbine

Tempering air case

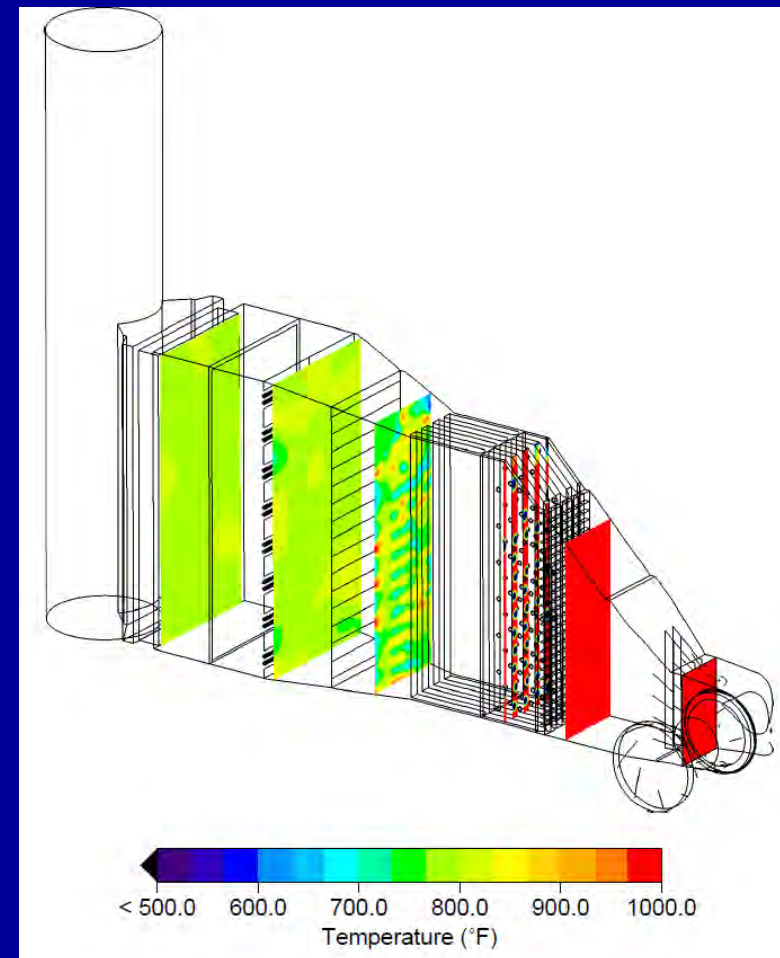

GT Design Objectives

❖ Turbine Inlet Conditions

- Can have inlet cooling systems
- Plant layout can affect turbine inlet conditions
- Condenser and exhaust plume interaction

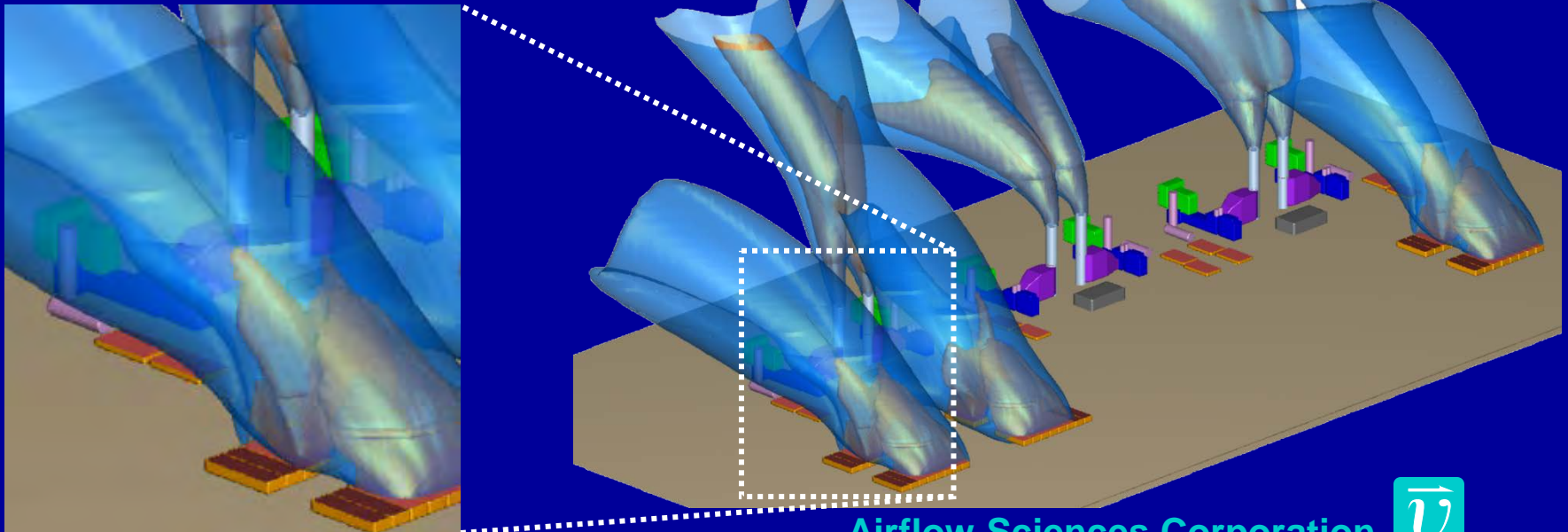

GT Design Objectives

❖ Ammonia Injection

- The key factor in deNO_x performance and ammonia slip
- Goal is uniform concentration (ammonia-to-NO_x ratio) at SCR catalyst
- General target is 5% RMS or better
- Optimization requires balance of competing goals
 - Velocity profile at AIG
 - Uniform injection from AIG nozzles
 - Mixing effectiveness
 - Pressure drop
- AIG design is not straight-forward
 - Mixing can be limited
 - Temperature heat up can affect distribution
 - Updated design practices have led to advances
 - Older systems likely have room for improvement

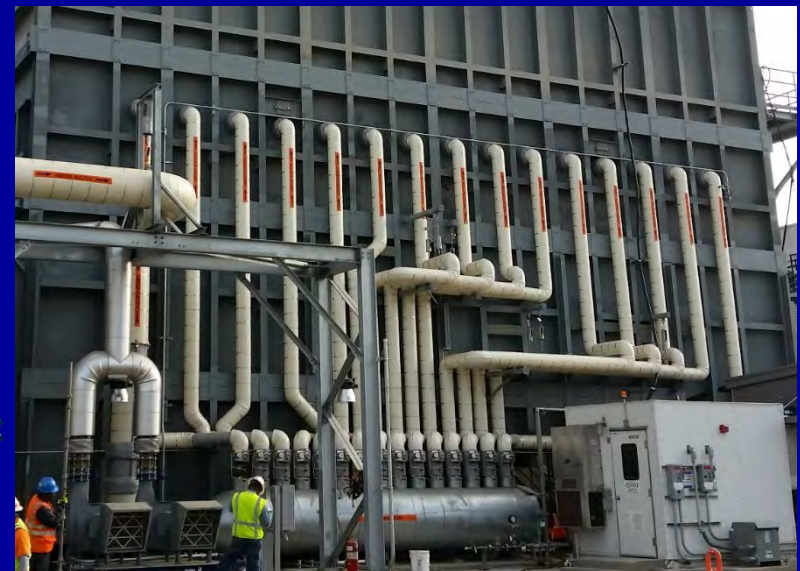

GT Design Objectives

❖ Ammonia Injection Grid

- General goal is to inject equal ammonia from each nozzle to within 2% or better
- Correct sizing of header ID, lance ID, and nozzle diameters is important
- May need to consider heat transfer from gas side to the internal pipe flow; this can influence the balance between nozzles
- The presence of tuning valves cannot always fix a poor design

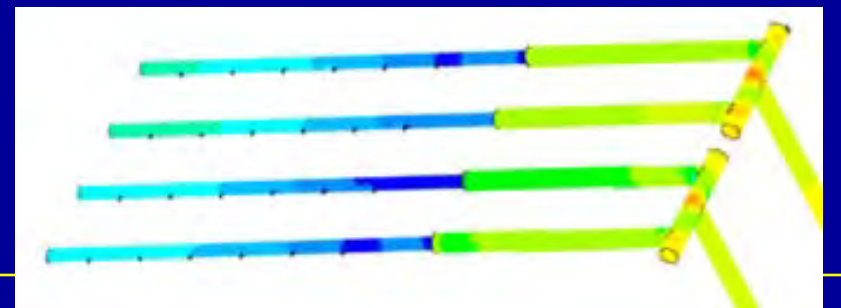
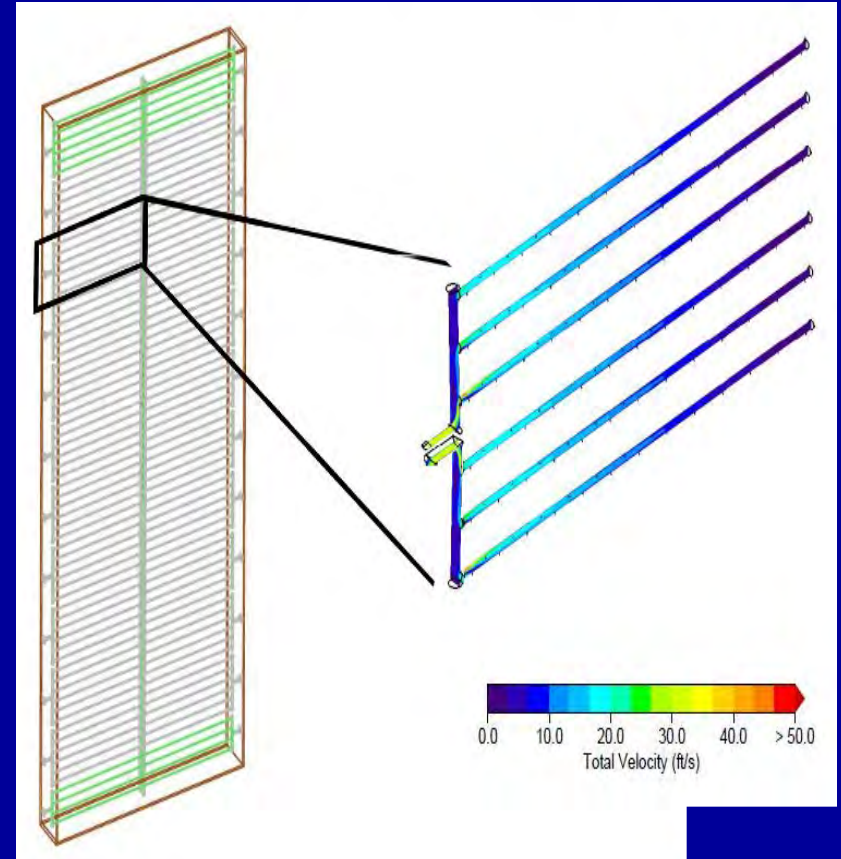

GT Design Objectives

❖ Ammonia Distribution at SCR

- Need to ensure sufficient number of lances/nozzles to cover the cross section
- Depends on residence time to catalyst and turbulence intensity
- Additional mixing may be required depending on geometry details
 - Static mixer after AIG
 - Turbulence generators integrated with AIG
- Determined through modeling, validated via testing

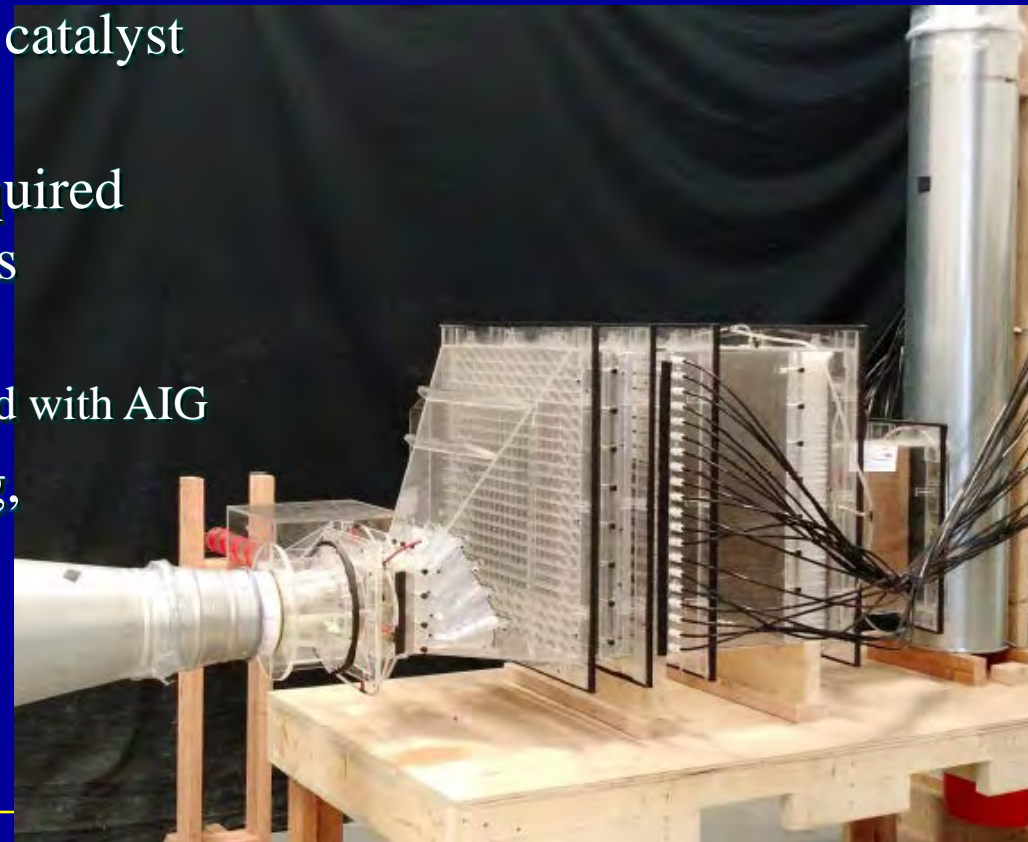

GT Design Objectives

❖ Pressure Drop

- Minimize
- This goal competes with all the other goals
- Balancing act is needed

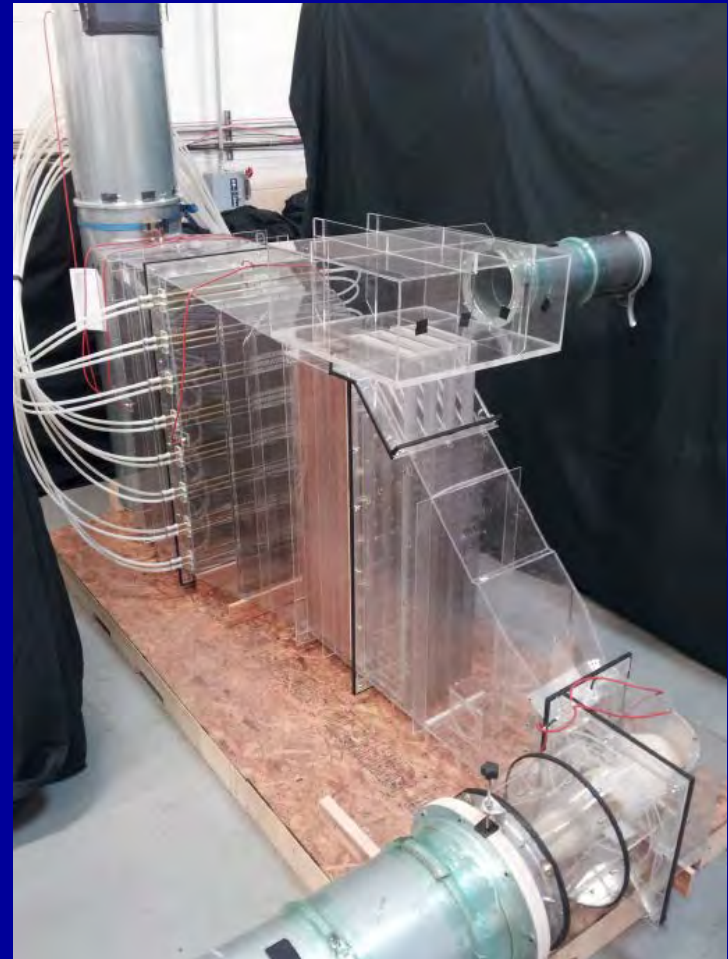
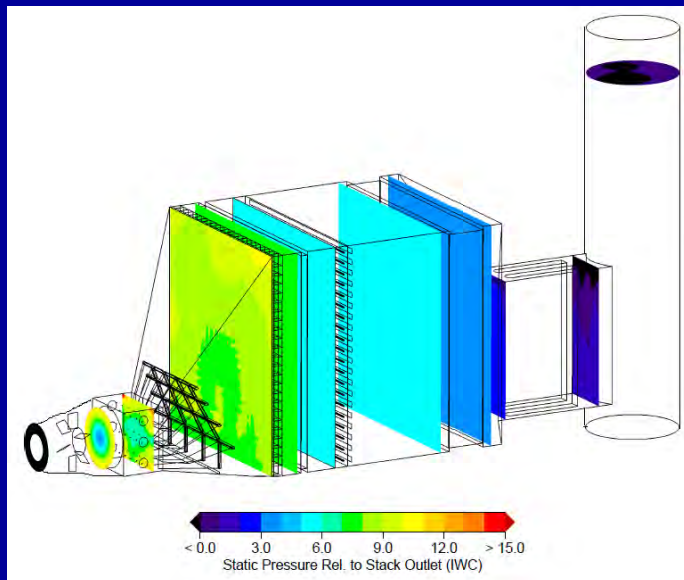

GT Conclusions

- ❖ There are many parameters that affect gas turbine and SCR performance
- ❖ Need optimized design at beginning, and design improvements over time
- ❖ AIG design and mixing play a critical role
- ❖ Cost-effective enhancements are possible to existing systems

Questions

